



Diesel Heating Catalogue - RV

Table of Contents

Air Top Diesel Heater Series	1
Air Top 2000 STC Diesel Heater Kit Contents.....	3
Air Top Evo 40 / 55 Diesel Heater	5
Thermo Top Diesel Water Heater Series	7
Isotemp Marine Water Heaters.....	9
Integrated EVO5 Hydronic Hot Water/Air Heater	11
Diesel Cooker X100	13
12 Litre Diesel Fuel Tank.....	15
Webasto Authorised Sales & Service Network.....	15

Air Heating

AIR TOP DIESEL HEATER SERIES



Webasto air heating systems are the ultimate choice when it comes to heating your leisure vehicle's interiors efficiently and economically.

The light weight and compact air heaters are easy and quick to install and can be used even whilst driving ensuring that you and your passengers arrive at your destination in a pre-warmed vehicle.

They quickly heat up the interior to the temperature you require, quietly ensuring that you enjoy constant, cozy warmth on board, where ever you choose to rest.

The Air Top range of heaters are cost efficient as they have low power and fuel consumption and operate independently to heat up the interior without having to have the engine running.

Product features:

- High comfort due to the very quiet operation and step-less power control
- Easy Installation in virtually all vehicles due to compact dimensions
- No engine idling
- Can be used whilst driving
- User-friendly operation
- Powerful with short heat up times
- Proven technology - Made in Germany
- Low fuel and power consumption
- Fuel supplied from motorhome's own tank
- Optional fuel tank available for caravans
- In-Built Diagnostic capability as standard on both controls



Standard Control

Simple turn the hand control dial to start the heater and warm up to set your desired temperature.



Programmable Digital Multi Control

Digital controller with easy to read screen, programming knob and Timer function.

Cross-section Air Heating system

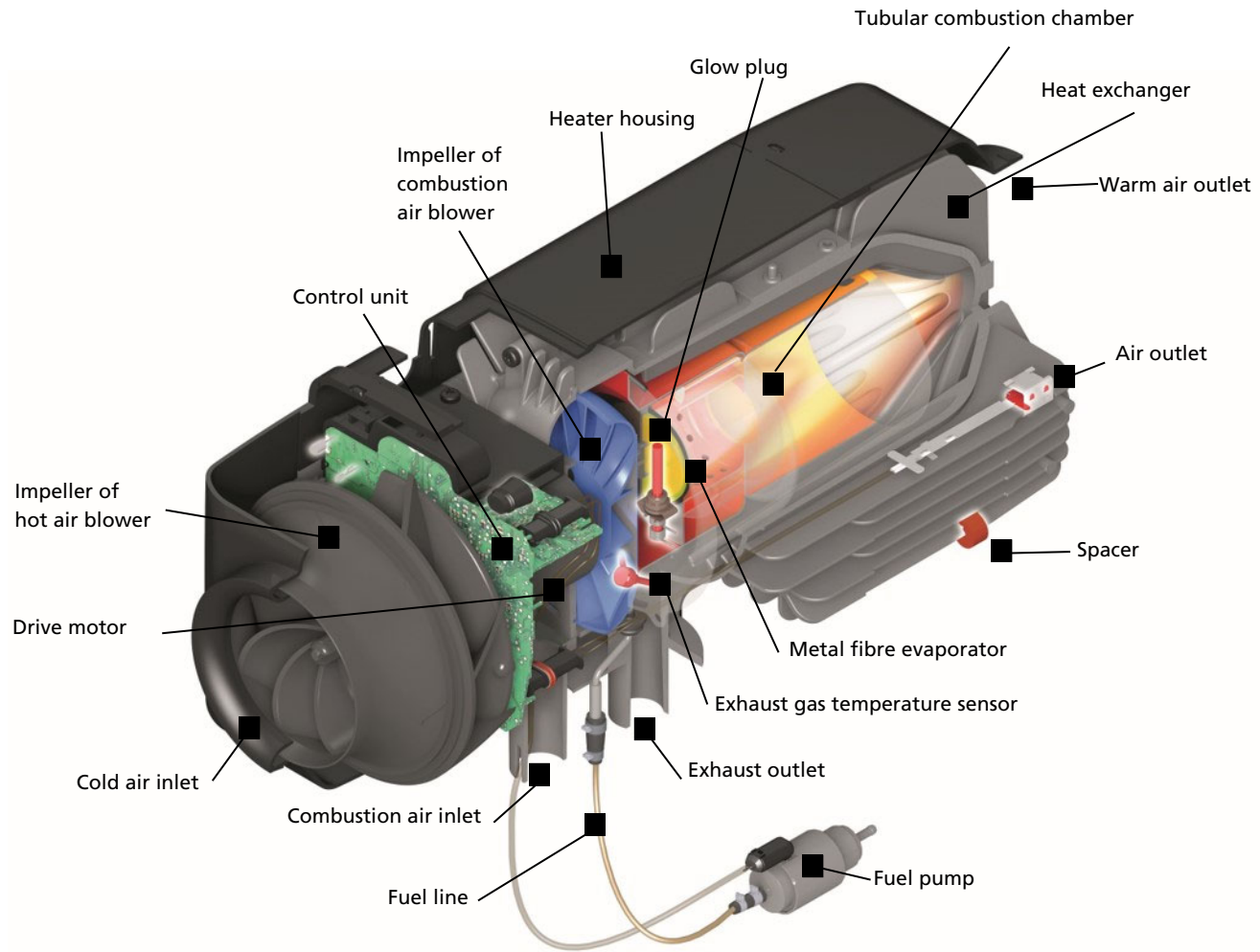

Technical Specifications

	Air Top 2000STC		Air Top EVO 40		Air Top EVO 55	
Voltage (V)	12	24	12	24	12	24
Fuel Type	Diesel		Diesel		Diesel	
Heat Output (kW) Partial Load - Full Load/Boost	0.9 - 2.0		1.5 - 3.5 / 4.0		1.5 - 5.0 / 5.5	
Fuel Consumption (L / hr) Partial Load - Full Load/Boost	0.12 - 0.24		0.18 - 0.43 / 0.49		0.18 - 0.61 / 0.67	
Power Consumption (W) Partial Load - Full Load/Boost	14 - 29		15 - 40 / 55		15 - 95 / 130	
Dimensions (LxWxH mm) Weight (kg)	311 x 120 x 121 2.6		423 x 148 x 162 5.9		423 x 148 x 162 5.9	

Air Heating

AIR TOP 2000 STC DIESEL HEATER

KIT CONTENTS



Item #	Description	Qty
1	AT2000STC	1
2	Fuel connector, fuel clamps, fuel filter & exhaust end cap	1
3	Fuel Pump Harness - 7m	1
4	Fuel Pump kit with mounting hardware	1
5	Exhaust Silencer with mounting hardware	1
6	Documents	1
7	RV Main Harness	1
8	Combustion Air Silencer, Combustion Air Intake (400mm), hose clamp	1
9	Rubber Mounting Gasket and Air Grille	1
10	620 Ohm Resistor	1

Accessories overview (part of kit)

		1 outlet	2 outlets
	Stainless Steel Floor mount heater bracket	1	1
	60mm ducting	1 Mtr	2 Mtr
	Duct Clamp 47-70mm	4	8
	Air outlet, 45°	1	1
	Air outlet, closeable		1
	Vent Collar	1	2
	Vent 60mm flat open	1	1
	Branch pipe 60x60x60mm		1
	Exhaust Pipe (0.8m)	1	1
	Fuel Line	6 Mtr	6 Mtr

Controllers



Rotary Control



Programmable Multi Control

Accessories Extra



12Ltr Fuel Tank with sight glass & quick connect



Fuel standpipe - Plastic Fuel Tank or Metal Fuel Tank versions available

Air Heating

AIR TOP EVO 40 / 55 DIESEL HEATER



The Air Top Evo diesel heaters offer greater comfort, safety and heating capacity for large recreational vehicles than their predecessors.

Available in 2 models - EVO 40 a 4kW unit or EVO 55 a 5.5kW unit - ensuring quick and efficient heating of cabins.

Energy consumption and noise are significantly reduced by the control system and intelligent fuel pump operation.

An automatic altitude compensation system is included as standard.

Quick and easy installation makes the Air Top Evo an economical retrofit solution.

The Air Top Evo 40/55 combines flexibility, functionality and product quality through innovation, while maintaining the traditional Webasto air heater design.

Product features:

- Heating capacity of 4 kW or 5.5 kW depending on unit.
- Low energy consumption
- Exceptionally quiet operation
- Continuous heating capacity due to low power consumption
- Automatic altitude compensation as standard
- A wide range of safety and comfort features
- ECU with improved humidity sealing
- A wide range of safety and comfort functions



Standard Control

Simply turn the hand control dial to start the heater and warm up to your desired temperature.



Programmable Digital Multi Control

Digital controller with easy to read screen, programming knob and Timer function

Technical Specifications

	Air Top EVO 40		Air Top EVO 55	
Heating capacity, control range/boost (kW)	1.5 - 3.5 / 4.0		1.5 - 5.0 / 5.5	
Fuel consumption, control range/boost (l/h)	0.18 - 0.43 / 0.49		0.18 - 0.61 / 0.67	
Nominal voltage (V)	12	24	12	24
Rated power consumption, control range/boost	15 - 40 / 55		15 - 95 / 130	
Heating air volume flow against 0.5mbar, control range/boost (m³/h)	132 / 140		200 / 220	
Fuel	Diesel		Diesel	
Operating temperature range (°C)	-40 to +40		-40 to +40	
Dimensions L x W x H (mm)	423 x 148 x 162		423 x 148 x 162	
Weight (kg)	5.9		5.9	
Automatic altitude compensation (m)	2,200		2,200	
ECE approval number ECE R122 (heating)	E1 00 0385		E1 00 0386	
ECE approval number ECE R10 (EMC)	E1 04 5529		E1 04 5529	

Water Heating

THERMO TOP DIESEL WATER HEATER SERIES

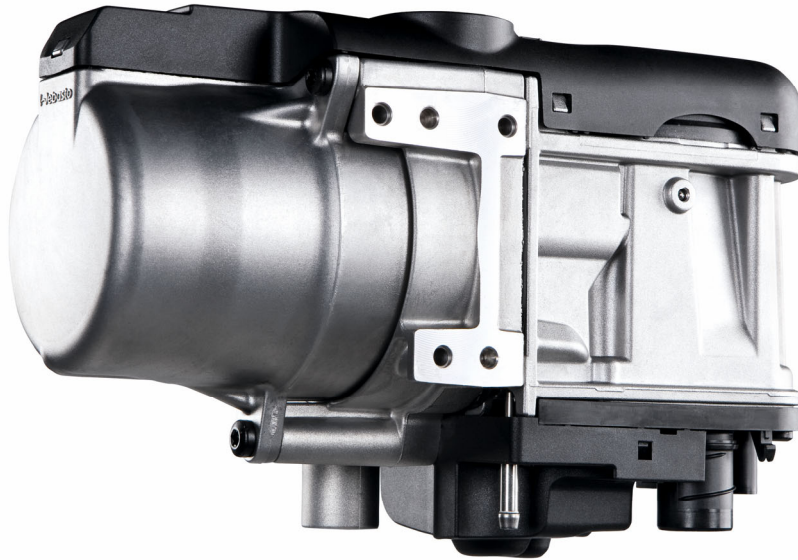

With the Webasto water heating system in your mobile home, and the heated air option, you'll be thoroughly spoiled. The practical water heating system for kitchen and bathroom means you have a supply of hot water for showering, washing, cooking and washing up. Depending on how it is incorporated, this system can also be used to provide heated air throughout the living area, so you can enjoy the level of cozy warmth you want at little additional costs. All the comfort of home even in the middle of nowhere.

Product features:

- 12 volt or 24 volt system
- Diesel fuel burner (one fuel source)
- Completely enclosed, no naked flame
- Electronic thermostat for constant controlled water temperature
- High output and short heat up time
- Quiet and economical to run
- Environmentally friendly (low emission)
- Low current draw
- Compact, space saving design
- Safe to operate (no gas)
- Operates independently of vehicle engine and external power supply
- Easy expansion of system to allow air heating for the living space

Technical Specifications

Model	Voltage		Fuel Type	Heat Output (kW) Partial Load - Full Load	Fuel Consumption (l/hr) Partial Load - Full Load	Power Consumption (W) Partial Load - Full Load	Dimensions LxWxH (mm)	Weight (kg)
Thermo Top EVO5	12		Diesel	2.5 - 5.0	0.31 - 0.62	12 -32	218 x 91 x 147	2.4
Thermo Pro 90	12	24	Diesel	1.8 - 7.6 variable 9.1 booster speed	0.21 - 0.92/1.14	37 -80	352 x 131 x 224	4.9
Buffer Tank 16L	-		-	-	-	-	500 x 170 x 280	7 Dry

System Layout

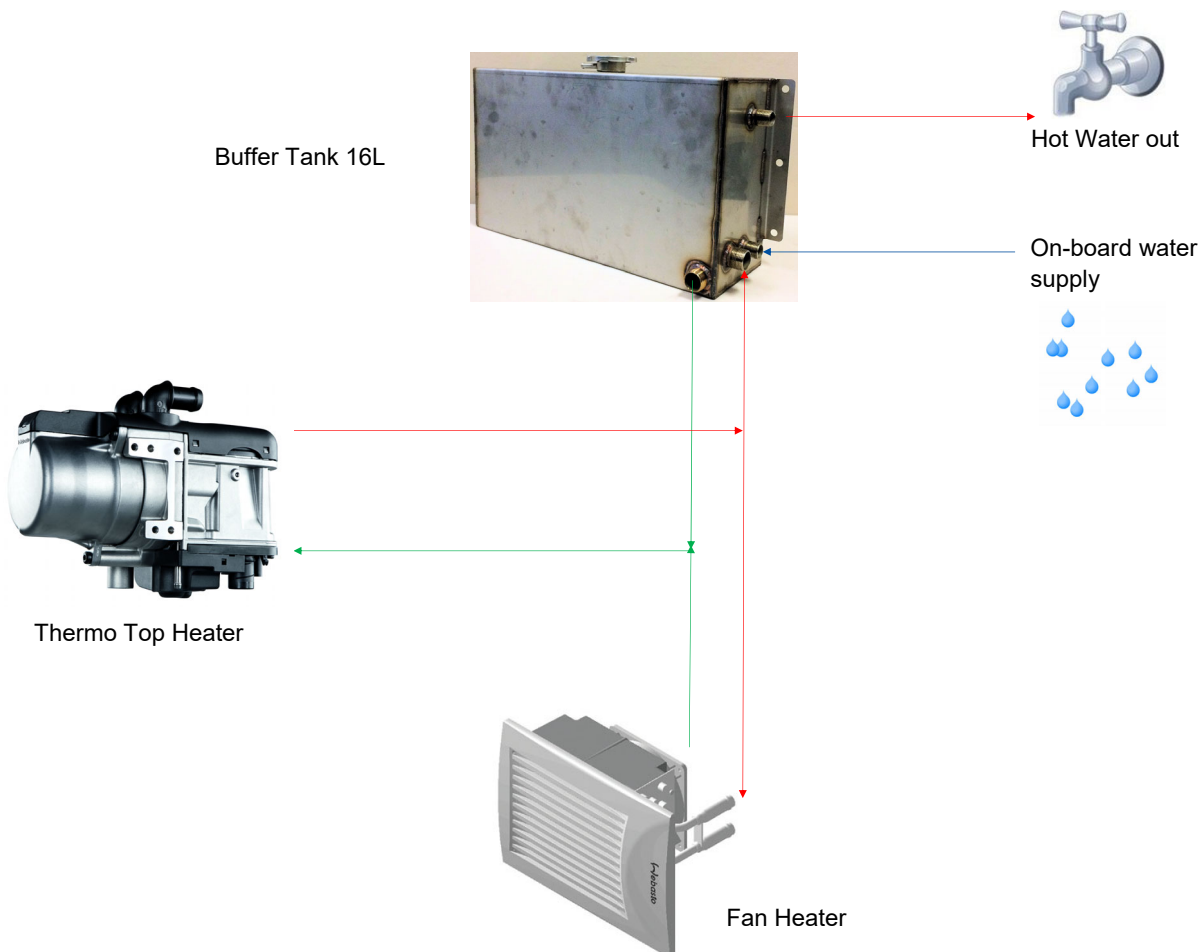

Water Heating

ISOTEMP MARINE WATER HEATERS



Isotemp water heaters are specifically designed for use on yachts and boats. Only high quality components are chosen to ensure the best product performance.

The Isotemp water heater comes with a brushed stainless steel cover as well as innovative internal design. It achieves highest capacity by optimised installation of the engine water heat exchanger as well as the immersion heater. They are positioned in the lowest part of the tank where the water is coldest in order to ensure an equal heating of all the water in the tank. The water inlets and outlets are especially designed to minimise the mixture of cold and hot water.

Product Specifications:

- Extra long, corrugated coils for high heat exchange efficiency
- Special 7.0 bar/100 psi safety valve: simple winter drain
- Ultra-thick insulation for lowest temperature loss
- Electrical plug and play immersion heating element, especially designed to heat the water at the bottom of the tank
- Thermostat mixing valve available as standard
- Immersion heating element available in 750, 1200 & 2000W
- 2000W heating element is only compatible on 230V versions

Product features:

- Robust design
- Water tank in stainless steel
- External cylinder in stainless steel
- Stable fixing feet in stainless steel
- 360° adjustable mounting for easy installation also on bulkhead

Technical Specifications

Slim and Basic	Volume (L)	Dimensions * L x øD mm	Weight (kg)	Max. pressure (bar)	Immersion heater** (V/W)
Slim 15	15	520 x 295	10.5	7.0	230/750
Slim 20	20	645 x 295	11.5	7.0	230/750
Slim 25	25	765 x 295	13.5	7.0	230/750
Basic 24	24	470 x 395	14.0	7.0	230/750
Basic 30	30	535 x 395	17.0	7.0	230/750
Basic 40	40	640 x 395	20.0	7.0	230/750
Basic 50	50	760 x 395	23.0	7.0	230/1200
Basic 75	75	1050 x 395	29.0	7.0	230/1200
Square		Dimensions * L x øD x W mm			
Square 16	16	400 x 180 x 560	16.0	5.5	230/750
Double coil		Dimensions * L x øD mm			
Basic 24	24	470 x 395	14.0	7.0	230/750
Basic 40	40	640 x 395	20.0	7.0	230/750
Basic 75	75	1050 x 395	29.0	7.0	230/1200

* Including thermostat mixing valve

** Immersion heater 115V/750W and 115V/1200W also available. Material: Tank, engine water coil and all connections AISI 316; Outside cover and mounting feet AISI 304; Electric immersion heater: Copper covered by Nickel; Insulation: Polyurethane; Water connections: ½" inside and outside NPT and BSP pipe thread. Changes of the specification may be done without prior notice.

Air and Water Heating

INTEGRATED EVO5 HYDRONIC HOT WATER/AIR HEATER



The EVO5 Hydronic, Integrated Hot Water System, is an industry benchmark for diesel fired hot water systems.

The unit comes pre-assembled and tested for easy installation and can be operated whilst on the move, providing hot water and/or warm air.

A Webasto Thermo Top Evo 5kW diesel furnace is mounted next to a 15L Buffer Tank which contains a Plate Heat Exchanger. This combination makes for a very compact unit. A Fan Heater is an optional extra to provide warm air.

The Thermo Top Evo 5 heats glycol that is stored in the Buffer Tank (to approximately 80°C). This heated coolant goes through the Plate Heat Exchanger that has on-board water going through it as well. The water is heated via heat transfer. By utilising rubber heater hoses and brass plumbing fittings, you can incorporate a Fan Heater to provide you with the comfort of warm air.

Product Features:

- Pre-assembled and tested for easy install
- Robust brass fittings
- Completely enclosed combustion process, no naked flame
- Plate mounting for heater easy access
- New Fuel Pump and Muffler
- Coolant circuit bleed valve
- Air Intake Silencer
- Can be operated whilst on the move
- Low current draw and fuel consumption
- Separate water pump
- Simplified wiring harness to suit RV Industry
- 2 year nationwide product warranty

Technical Specifications

EVO5 Hydronic

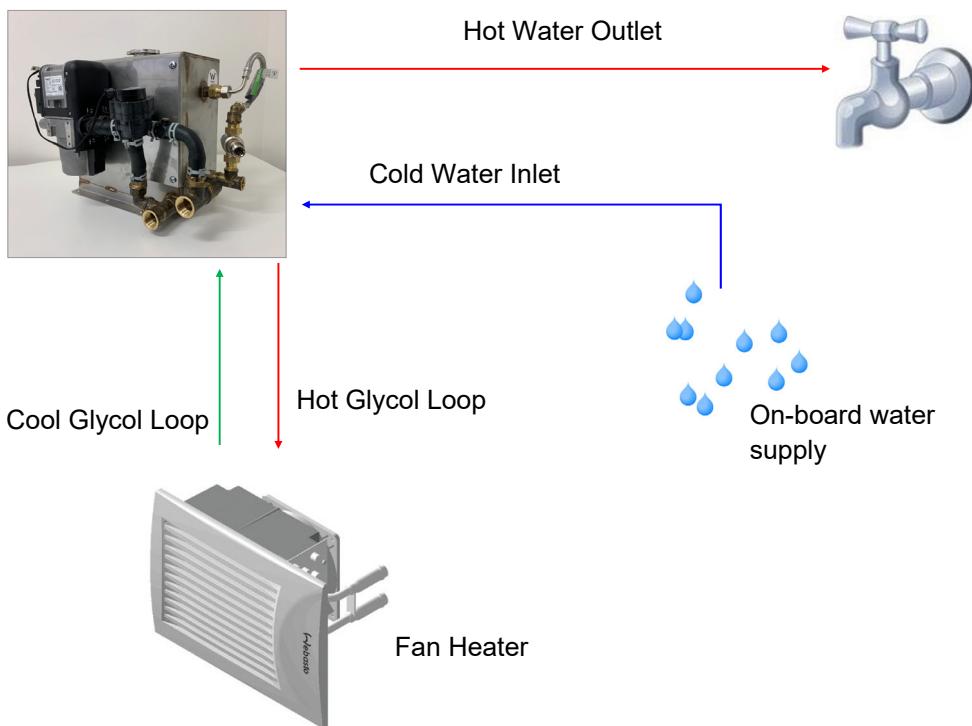

Heated Water Temperature (°C)	38 - 50°C
Heating Time (min.) *	20
Re-Heat (min.)	15
Power Consumption (W)	12 - 33
Partial Load - Full Load	
Fuel Consumption (L/Hr)	0.31 - 0.62
Fuel Type	Diesel
Voltage (V)	12V
Dimensions (LxWxH mm)	400 x 265 x 350



All EVO5 Hydronic components* within the Webasto heated water service, that come into contact with drinking water, are WaterMark compliant and certified. AS 3498 / Certificate No. 23211

* Plate Heat Exchanger, Thermostatic Mixing Valve and Brass Fittings.

Cooking - Independent cooking solution for the RV Market

DIESEL COOKER

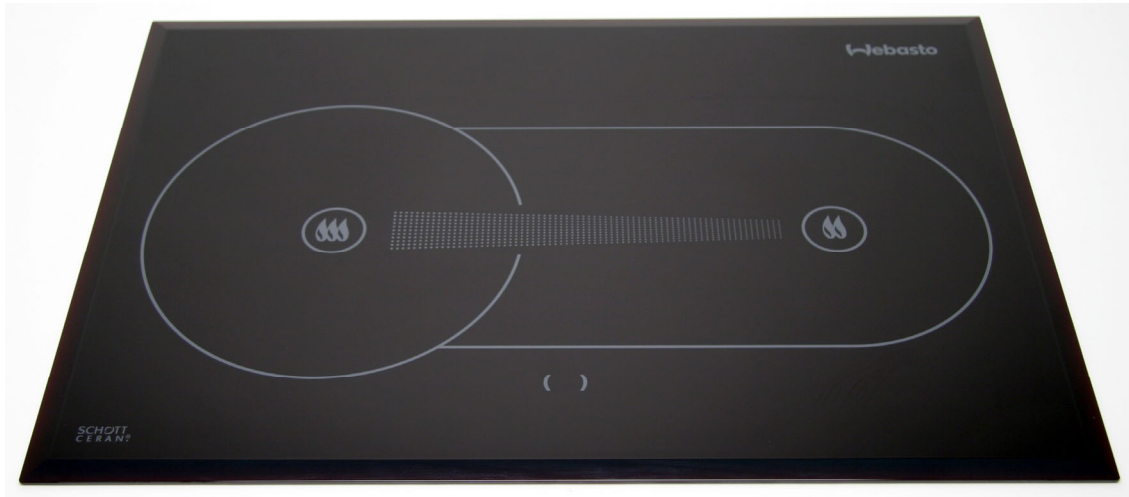

In general, cooking in a camper van means cooking with gas. However practical this is, it is questionable in terms of design, cleanliness, and safety. And what happens when the gas cylinder is empty? Webasto has the solution:

The Webasto Diesel Cooker X100

The heat source for this cooker is a diesel burner which is integrated into the cooker. This heats a CERAN® cooking surface which has room for two small pots or saucepans. Only the glass ceramic cooking surface is visible, this is very robust and easy to care for, just like at home.

Inside the van there is no open flame, the exhaust is led to the outside - in the same way as Webasto diesel heaters.

Product features:

- Elegant design
- Very safe thanks to absence of open flames
- Easy to use by means of control unit with installation adaptability
- Easy to clean
- Low current and fuel consumption
- Really quiet
- Exhaust exiting to the outside
- Hotplate displays residual heat
- High cooking power up to 1,800 Watt
- Full functionality at high altitude (above 1800m)
- Robust, high-quality CERAN® cooking surface
- Rapid installation thanks to universal installation kit

Installation Diagram for the Webasto Diesel Cooker X100

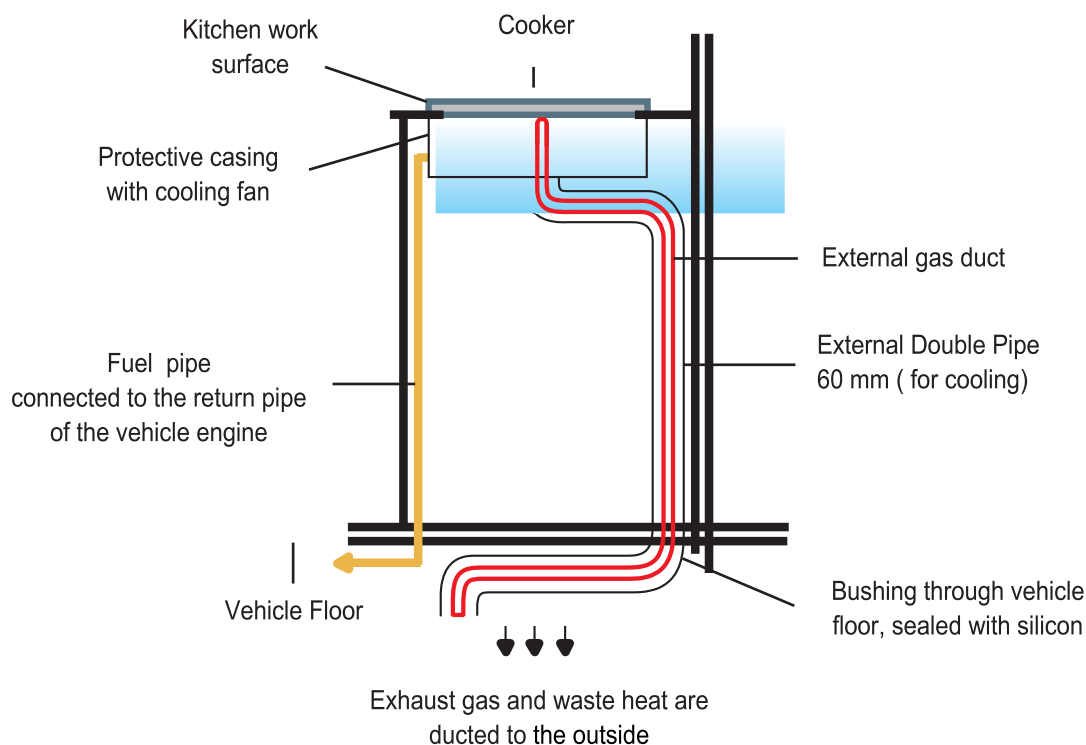

The cooker can be installed without difficulty in most vehicles. The cooker is inserted from above into the recess in the kitchen work surface. The protective casing is fitted from below, and has an integrated cooling fan which ensures that the waste heat is ducted from the underside of the cooker to the outside via a flexible coaxial pipe.

Technical Specifications

Cooking power (KW)	0.9 - 1.9
Power consumption (A)	0.3 (max. at start-up approx. 8 A for 4 min.)
Fuel	Diesel
Fuel Consumption	0.09 - 0.18
Start-up time (min)	~ 3
Rated Voltage (V)	12
Dimension of CERAN® hot plate LxWxH(mm)	466 x 316 x 50
Dimension of protective casing LxWxH(mm)	565 x 366 x 172 (2cm waste air nozzle)
Weight (Kg)	8 (hot plate) 1.5 (casing)



Control panel

Fuel Tank

12 LITRE DIESEL FUEL TANK

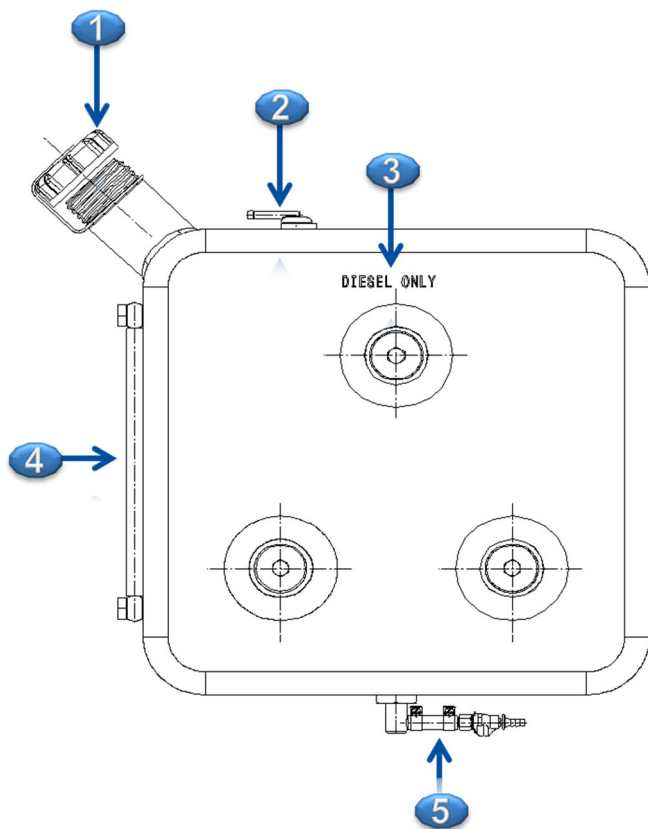

1. The filler neck of the auxiliary tank is equipped with a twist-off cap with a plastic tab to secure it against loss.
2. A ventilation and bleeder valve with an integrated roll-over function is located on top of the additional tank.
3. A warning on the fuel to be used is provided in raised letters on both sides of the additional tank.
4. A fuel gauge in the form of a sight level gauge is located below the filler neck.
5. A quick-release coupling is located on the bottom of the tank.













Tank Dimensions - 405 x 405 x 94mm

WEBASTO AUTHORISED SALES & SERVICE NETWORK

NSW	A One Caravan Repairs Unit 2, 1 Kite Street EMU PLAINS 2750	02 4572 7176 Peter Cleland	\$	
	ABCO Caravan Services 6 Collison Place COFFS HARBOUR 2450	02 6651 2445 Tracee	\$	
	Albury Wodonga RV World 1A Watson Street WODONGA 3690	02 6024 4222 Matthew Wilson	\$	
	Australian Motor Homes 31 Pacific Hwy BENNETTS GREEN 2290	02 4948 0433	\$	
	Newcastle Caravan Repairs 63 Pendlebury Road CARDIFF 2285	02 4956 6036 Scott Lehman	\$	
	Outback Vehicle Accessories 431 Thirlmere Way THIRLMERE 2572	0417 250 369 Paul Flint	\$	
	Premium Caravan & Motorhome Services 17/25-31 Airds Road MINTO 2566	0404 121 925 Danie Johanson	\$	
	RVGO Unit H, 26-30 Tepko Road TERREY HILLS 2084	02 9986 2952 Michael Major	\$	
	Ulladulla RV Repair Centre 15 Witherington Avenue ULLADULLA 2539	02 4455 6127 Luke Ryan	\$	
	Wagga Car Radio 379 Edward Street WAGGA WAGGA 2650	02 6925 6111 Dan Grundy	\$	

Dealer Network

WEBASTO AUTHORISED SALES & SERVICE NETWORK

VIC	Advantage Caravan Repairs 23 Thomycroft Street, CAMPBELLFIELD 3061	03 8339 0772	\$	
	Canterbury Caravans 587-589 Dorset Road BAYSWATER NORTH 3153	03 9729 8188 David Cooke	\$	
	Carac 2 Zenith Road DANDENONG 3175	03 9794 7977	\$	
	Caravan Repair Specialists 22 Silkwood Rise CURRUM DOWNS VIC 3201	03 9775 1213 Stuart Oakley	\$	
	Cool Factor 5/314 Governor Road BRAESIDE 3195	03 9587 5244 Noel Thomas	\$	
	Retro Looms 42 Renver Road CLAYTON 3168	03 8521 3021 Darren Hellenen	\$	
	RV Sales Centre (THL) Central West Business Park, Building 2, 9 Ashley Street BRAYBROOK 3019	03 8398 8848	\$	
	Solar City Caravan Service 25/27 Apollo Drive SHEPPARTON 3630	03 5831 4712 Craig	\$	
	Trans Air & Electrics 12 Piper Road EAST BENDIGO 3350	0429 842 644 Steve Bobin	\$	
QLD	Brad's Car, Caravan & RV Servicing & Repairs 14 John Street ALLENTOWN 4700	0488 025 080 Brad	\$	
	Caravan & RV Works 12-14 Enterprise Street KUNDA PARK 4556	07 5445 6662 Peter Lawson	\$	
	Suncoast Caravan Service 33 Fishermans Road MAROOCHYDORE 4558	07 5443 1036	\$	
	VanGo Caravan Services 1/74 Perrin Drive UNDERWOOD 4119	07 3209 5044 Garry Hogarth	\$	
SA	Diesel Heating Specialists	0405 737 871 Ian Hume	\$	
	Jayco Mount Gambier 2 Brian Smith Drive SUTTONTOWN 5291	08 8725 6122 Jason Pignotti	\$	
ACT	Technic Trim & Sunroofs 2/1 Sawmill Circuit HUME 2606	02 6260 2487 Jason Borg	\$	
WA	The Camper Tamperer 5 Ditchingham Place AUSTRALIND WA 6233	08 9768 0674 Brad Mains	\$	
	Perth Mobile Caravan Service & Repair Perth Metro - Baldivis WA 6171	0419 912 198 Jamie Reeves	\$	
	Pilgrim RV 10/9 Inspiration Drive WANGARA 6065	08 9303 4494 Aaron Pilgrim	\$	
TAS	Able Marine 61 Ferry Road KETTERING 7155	03 6267 5031 Angelo Perry	\$	
	Tas Mobile Caravan Service 83 Meander Valley Road WESTBURY 7303	0458 615 003 Peter Booth	\$	

Webasto Thermo & Comfort Australia Pty Ltd
423-427 The Boulevard, Kirrawee NSW 2232 Australia

Ph: +61 (0)2 8536 4800
svc-info@webasto.com
www.webasto.com