

Water heaters for the RV market

Thermo Top Evo

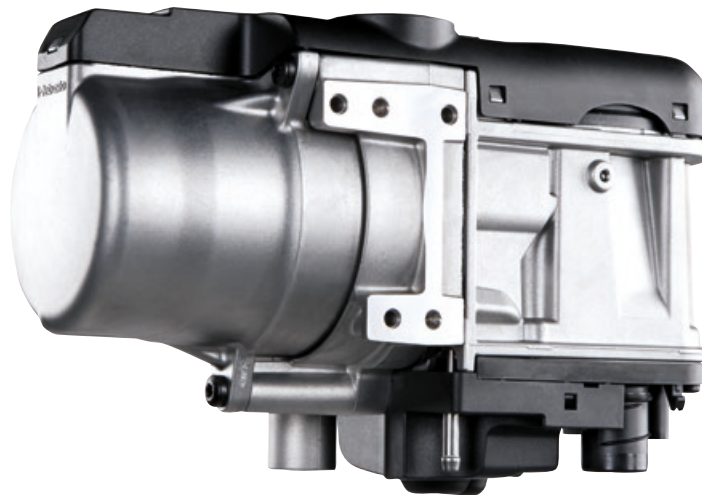

Webasto water heaters are ideal supplementary heaters that utilize the vehicle's own heating and ventilation system to provide a dedicated heating system for the driver's compartment.

The supplementary heater is mounted in the engine compartment and is integrated into the water circuit of the vehicle, in order to provide either dedicated heating to the driver's compartment or engine pre-heating.

Key benefits at a glance:

- Stepless heating power adjustment between 2.5 and 5 kW
- Smallest heater on the market
- More comfort in the front of the vehicle thanks to warmth supplied via the air outlets in the dashboard
- Operated by the MultiControl
- Very fast heat-up phase
- Low noise

Application concept

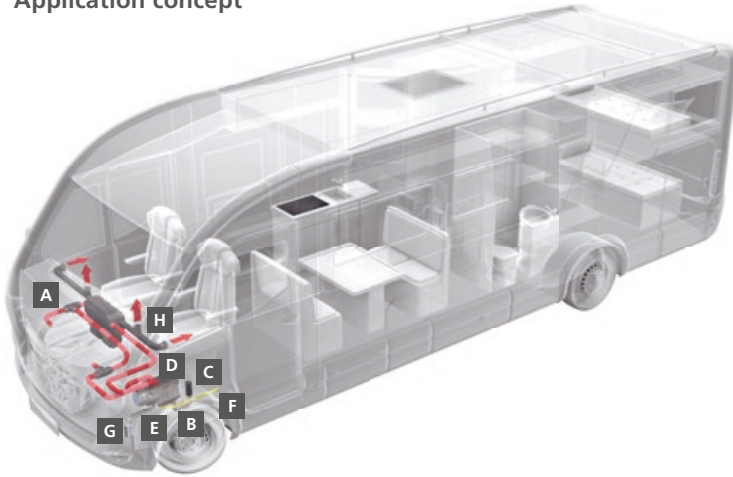

- A** Check valve
- B** Combustion air intake
- C** Intake silencer
- D** Water pump and water input
- E** Exhaust pipe
- F** Fuel pipe to vehicle fuel tank or to fuel return pipe
- G** Exhaust silencer
- H** Hot water output

Technical specifications

	Thermo Top Evo
Heating power (kW)	2.5 – 5.0
Fuel	Diesel
Fuel consumption (l/h)	0.31 – 0.62
Rated voltage (V)	12
Operating voltage range (V)	11 – 16.5
Rated power consumption (W)	12 – 33
Dimensions L x W x H (mm)	218 x 91 x 147
Weight (kg)	2.1

Controls



MultiControl

The MultiControl sets new standards in terms of its modern design and user-friendliness that allows fast and intuitive operation. It includes features like an immediate start button, the ventilation function and fault code display. You can program up to three start times per day for your heater which allows the best individual comfort.



ThermoCall App

Even greater comfort with our innovative Webasto ThermoCall App. Run your water or air heater easily with a smartphone via App for iOS and Android device.