

## Thermo Pro 50 Eco

Compact and Powerful Coolant Heater for Professional Applications

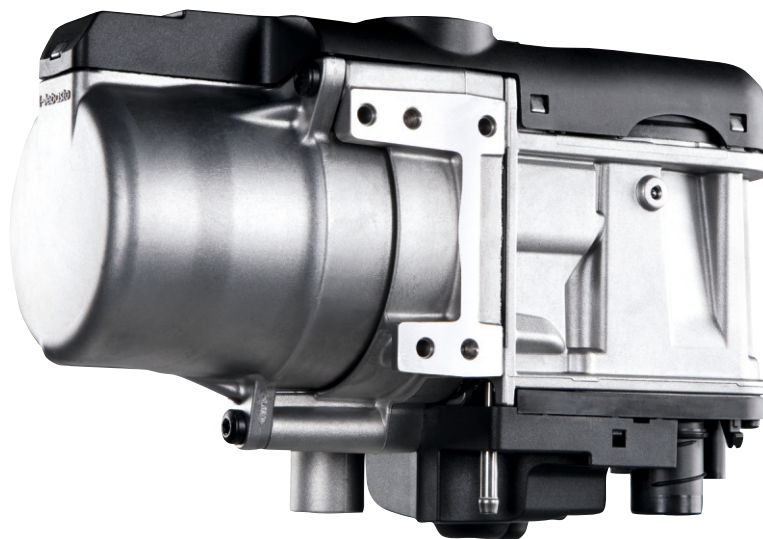

The Thermo Pro 50 Eco heater has been specially designed for use in lightweight trucks and small to medium-sized commercial vehicles.

Its compact dimensions and lightweight design allow it to be integrated in vehicles with limited installation space.

With additional time-tested features, such as an automatic altitude adjustment, Arctic Start and continuous heating control, extreme environmental conditions can be managed easily.

By efficient engine pre-heating, the Thermo Pro 50 Eco guarantees prolonged vehicle's availability, cost-saving operation and less material wear, even in harsh environmental conditions.

### Key Benefits at a Glance:

- Engine-independent water heater with 2.5 to 5 kW of heating power
- High product quality with a service life of 3,000 hours
- Especially economical and lower in emissions thanks to efficient heating power control
- Standard altitude adjustment up to 3,000 m variant with operator up to 4,000 m available
- Available for initial installation and retrofitting



Truck



Light Vehicles



Defense



Off-Highway



Special Vehicles

## Technical Specifications

	Thermo Pro 50 Eco
	Diesel
ECE approval number ECE R122 (heating)	E1 00 0471
ECE approval number ECE R10 (EMC)	E1 06 7609
Heating capacity, part load/full load (kW)	2.5 / 5.0
Fuel consumption, part load/full load (l/h)	0.3 / 0.6
Nominal voltage (V)	24
Nominal power consumption without coolant pump, part load / full load (W)	28 - 46
Fuels	Diesel DIN EN 590; Diesel B20-B30 DIN EN 16709;
Operating temperature range (°C)	-40 to +80
Dimensions L x W x H (mm)	218 x 91 x 147
Weight (kg)	2.2
Permissible High Altitude Level above sea level (m)	Thermo Pro 50 Eco: up to 3,000 m Thermo Pro 50 Eco HA: up to 4,000 m
	Coolant pump U4847
Nominal power consumption (W)	3.6 - 13.9
Volume flow against 0.31 bar (l/h)	500
Dimensions L x W x H (mm)	96 x 75 x 80
Weight (kg)	0.28

### Scope of Delivery:

- Standard Thermo Pro 50 Eco
- Coolant pump U4847
- Fuel pump DP42
- Product documentation basic

### Installation Kit Universal:

- Standard electrical kit with wiring harness
- Exhaust silencer with standard pipes
- Intake silencer with pipe
- Set-off fuel line with mounting parts
- Water hoses and connectors

### Vehicle & Market Specific Kits (Alternative to Standard Kit):

- Individual vehicle specific application

### Recommended Control Elements

#### Rocker Switch:

- Operation indicator and fault display by blink code
- Cover panel dimensions (L x W): 23 x 23 mm (drilling hole 20 mm, necessary)



### ThermoConnect:

- Convenient control of connected Webasto parking heater
- Info such as status of the heater, interior temperature and vehicle position
- Utilize GPS position of the vehicle
- Heating or ventilation mode



(ThermoConnect is not available in Turkey)

### MultiControl:

- Intuitive user interface
- 7-day timer function
- Ventilation function
- Quick and easy dashboard installation
- High altitude functionality of up to 3,000 m



### UniControl:

- Mounted via universal DIN slot
- Quick and intuitive operation
- Individual operating time between 10 - 120 minutes or continuous heating
- Instrument lighting & Ignition plus
- Suitable for use in vehicles for the transport of dangerous goods (ADR)

